

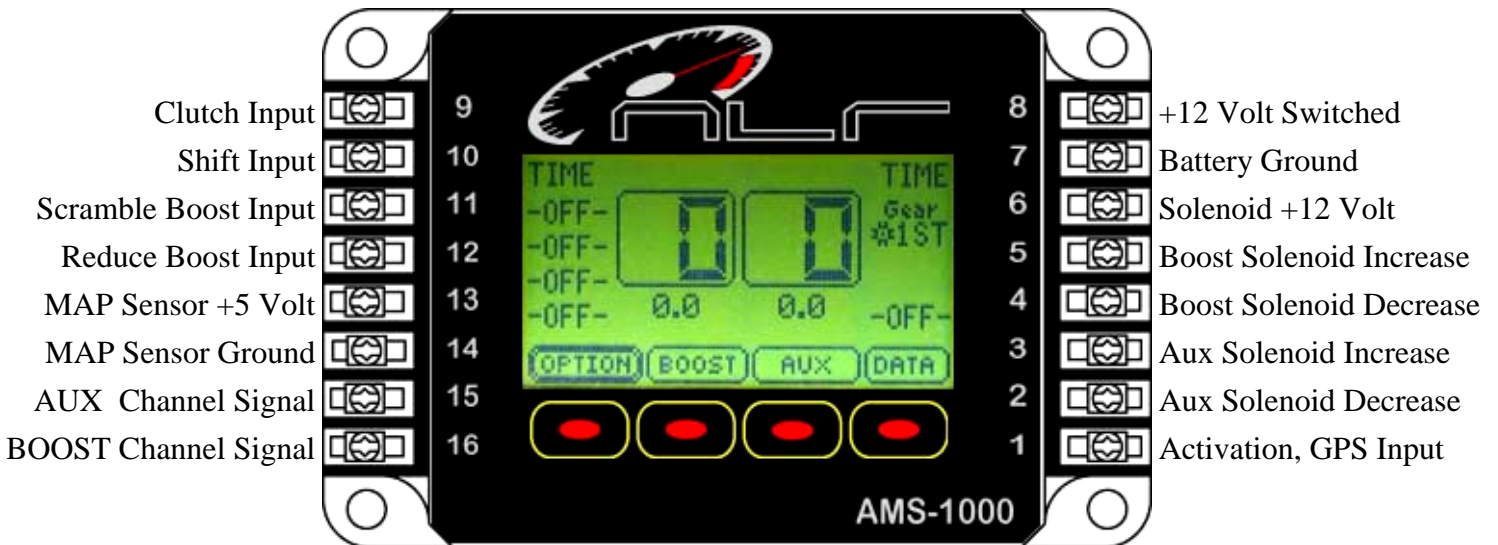

# AMS-1000

## Multi-Channel Air Management System for Boost Control

The terminal pin descriptions may also be viewed on screen. See [Page 24](#) of manual for details.



**IMPORTANT—A sensor MUST be connected to the Boost channel. If no Sensor is present a Warning Message will be displayed!**

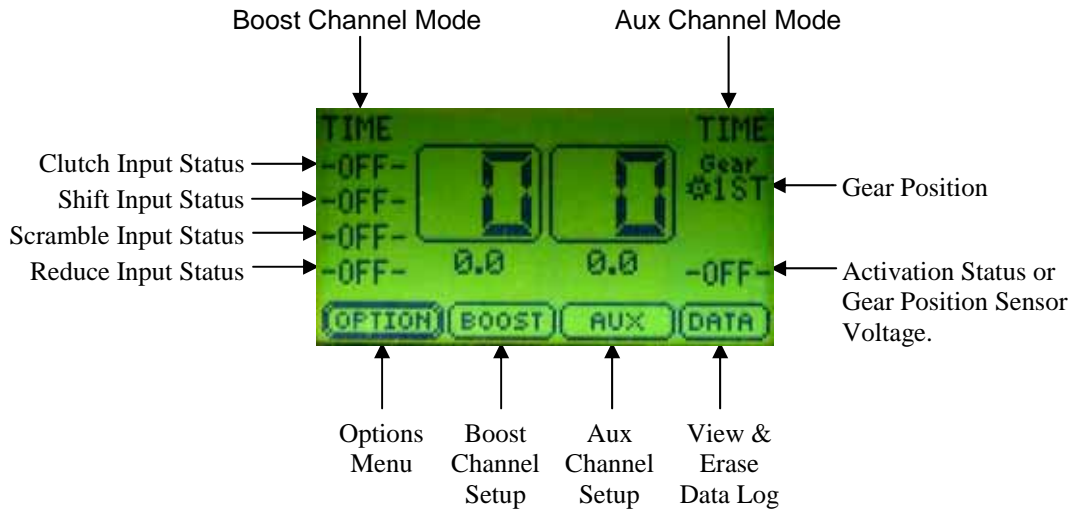

Copyright © 2005, All Rights Reserved, NLR, LLC

**NOTE—Target Psi is the amount applied to the waste gate and is NOT the actual Manifold Boost Psi!**



## Notice:

It is the responsibility of the purchaser to follow all guidelines and safety procedures supplied with this product and any other manufactures product used with the AMS-1000. It is also the responsibility of the purchaser to determine compatibility of the AMS-1000 with the vehicle and other components.

NLR, LLC assumes no responsibility for damages resulting from accident, improper installation, misuse, abuse, improper operation, lack of reasonable care, or all previously stated reasons due to incompatibility with other manufacturer's products.

NLR, LLC assumes no responsibility or liability for damages incurred from the use of products manufactured or sold by NLR, LLC on vehicles used for competition racing.

NLR, LLC neither recommends nor approves the use of products manufactured or sold by NLR, LLC on vehicles which may be driven on public highways or roads, and assumes no responsibility for damages incurred from such use.

NLR, LLC does not recommend nor condone the use of its products for illegal street racing.

**Installation of NLR, LLC products signifies that you have read this document and agree to the terms stated within.**

## Important Information:

Please see last page for Quick Tech Tips!

Follow all recommended safety guidelines from this and other manufactures installation guides.

Static suppression ignition wires must be used with this unit! Mount the unit as far away from secondary ignition components (coil, ignition wires, etc.) as physically possible.



**Description**—The AMS-1000 multi-channel Air Management System represents the latest in Digital Technology. A Motorola 50-Mhz 16-bit processor is used to provide accurate and extremely fast control. A 128x64 pixel Graphical LCD Display is used to provide a Live display of Data and Inputs. GUI (Graphical User Interface) style operating system makes setup and programming more intuitive and user friendly.

Data logging is integrated into the AMS-1000 and provides the user with instant feedback on the performance and real time operating parameters. The Data is presented as a Graph with a Scroll function for detailed data information. If only the main Boost channel is used for control of a waste gate the Aux channel MAP Sensor input can be used to log actual manifold pressure. If both channels are used for control then the logged data will represent the real time pressure applied to each channel during operation.

Support for multiple type and pressure range MAP sensors have been provided so the system can be tailored to an individuals needs. Sensor inputs are continuously monitored and any Error conditions are reported to the user.

- GM 3 bar—0 to 30 psi range.
- SSI 5 bar—0 to 60 psi range.
- SSI 6.5 bar—0 to 99 psi range.

Multiple operating modes available, Time Based, Shift Based, and GPS (Gear Position Sensor) Based.

**Time Based**—One to six timed stages are available with this mode of operation. Each stage has an adjustable timer to control the duration. The Ramp Rate (rate at which the pressure is applied) is adjustable from 0 to 100 psi per second. A Ramp Rate setting of 0 does not disable the stage. The target psi will instantly rise at the end of any timed stage with a 0 Ramp Rate setting. The target psi can be increased or decreased over time to achieve the desired Boost Profile.

**Shift Based**—One to six stages are available and are controlled by a Shift Input signal. The Ramp Rate for each stage is programmable as well as the Target psi for each stage (gear position). The Ramp Rate settings perform the same functions as in Time Based mode.

**GPS Based**—One to six stages are available and are controlled by a 0-5 volt analog Input signal. This mode is for newer sport bikes or any vehicle that produces a different voltage for each gear position. A switch that produces a different voltage for each position can be used to select different boost profiles (up to six) on vehicles that do not use a Gear Position Sensor system. The Ramp Rate for each stage is programmable as well as the Target psi for each stage (gear position). The Ramp Rate settings perform the same functions as in Time Based mode. Data logging is NOT available with this mode of operation.



Multiple control inputs, Launch, Shift, Scramble, and Reduce inputs. These control inputs can be configured through the Options menu to be Active with either a +12 volt or a Ground signal.

**Clutch Input**—When active the Launch Target psi for each channel will be applied. The Launch Target psi can be set by the user through the Options Menu. When the Clutch Input is ON the Activation Signal is Ignored until the Launch signal is removed. i.e.—The controller will ignore the Activation Input signal while the Clutch Input signal is ON. An activation/timer reset option can be used with the Clutch Input, see the Option menu settings for more details.

**Shift Input**—A signal applied to this input will increment the Gear Position counter when the Activation Input is ON. The gear counter can be Reset each time a Clutch Input signal is recognized. Normal operation is that the Gear Counter is only Reset when the Activation signal is removed. See the Option menu settings for more details.

**Scramble Input**—The Scramble Input allows the user to increase or Scramble the target psi by a programmed amount. The Scramble function will function even if the Activation Input is OFF. The amount of Scramble increase is always added to the current target psi. See the Option menu for details on setting the Scramble increase amount. This function only is only applied to the Boost channel. There is no Scramble function for the Aux channel.

**Reduce Input**—The Reduce Input allows the user to decrease or Reduce the target psi by a programmed amount. The Reduce function will function even if the Activation Input is OFF. The amount of Reduce decrease is always subtracted from the current target psi. See the Option menu for details on setting the Reduce decrease amount. This function only is only applied to the Boost channel. There is no Reduce function for the Aux channel.

**Activation Input**—The Activation input control the start of the Stage timers and Ramp Rate timers. The Activation input is ignored if the Clutch input is ON. Data logging will always begin when the Activation input is first turned ON, even if the Clutch Input is Active. The Activation input can have a Hold-and-Wait timer that is programmed by the user. i.e.—If the user programmed a Hold-and-Wait value of .05 second the Activation input will not turn OFF for .05 seconds when the signal is removed. See the Option menu for more details.

The Activation input is also used for the GPS (gear position sensor) input if the AMS-1000 is configured for GPS Mode. See the Boost setup menu for more details.



## AMS-1000 Features:

- 1—Billet aluminum enclosure and all parts are specified over an extended temperature range.
- 2—Vibration and weather proof.
- 3—System software can be erased and reprogrammed by the factory for future software updates.
- 4—User settings will remain for up to 20 years with no power applied. No back up batteries are needed.
- 5—Factory default RESET available in the options menu to restore controller to state it was out of the box from the factory.
- 6—Launch mode programmable to range of selected MAP sensor.
- 7—Scramble boost to apply an amount of pressure that you program to the gate, thus increasing boost no matter where in the main program you are currently at. Think of it as an emergency boost button (kinda like a shot of nitrous) Remove the signal and it goes back to current target psi. Can be used as a single stage of boost
- 8— Reduce boost which works the opposite of scramble. It will remove a programmed amount from the current target psi. If you spin stab a button and it will reduce power instantly.
- 9—Delay timer for Activation in Shift Based Mode and First stage of Time based mode may be used as a delay timer.
- 10—Multiple operating modes:
  - Time Based (up to 6 stages) programmable to 1 hundredth of a second.
  - Shift Based (up to 6 stages)
  - GPS (up to 6 gears), self learning, can be used on anything with a voltage output to indicate gear position.
- 11—Programmable Ramp Rate to control the rate at which the pressure is applied. 0 to 100 psi range.
- 12—Dual output channels available or the auxiliary channel may be used for live boost pressure data viewing and data logging. Basically there are 2 controllers in 1 box. You can control multiple waste gate , valves, blow offs on supercharged systems thus giving you boost control.
- 13—Integrated Dual channel data logger with 35 seconds of record for each channel. Graph view of logged data. Logged data will remain until it is erased by user.
- 14—Graph view of programmed settings.
- 15—Display backlight and contrast is user adjustable from the options menu.
- 16—Help screens and setup wizards to help with setup.
- 17—Most inputs can be configured for + 12volt or ground activation.
- 18—All inputs have input protection diodes. All outputs have integrated noise suppression devices to clamp fly back voltage from solenoids.
- 19—Outputs short circuit protected and over current protected( 7 amp Maximum)
- 20—Reverse battery protection.

5 **NOTE—Target Psi is the amount applied to the waste gate and is NOT the actual Manifold Boost Psi!**



## Table of Contents:

<b>Notice and Important Information</b> Important information and Cautions	<a href="#">Page 2</a>
<b>AMS-1000 Description</b> General Overview and Operation	<a href="#">Page 3, 4</a>
<b>AMS-1000 Features</b> AMS-1000 Features	<a href="#">Page 5</a>
<b>OPTION Menu, Page1</b> Selecting MAP Sensor Setting Launch Psi, Boost and Aux Channels	<a href="#">Page 7</a> <a href="#">Page 7, 8</a>
<b>OPTION Menu, Page2</b> Setting Scramble and Reduce Psi, Boost Channel Setting Activation Hold and Clutch Reset Style	<a href="#">Page 8</a> <a href="#">Page 9</a>
<b>OPTION Menu, Page3</b> Turning the Aux channel On/OFF Setting Launch, Shift, Scramble, and Reduce polarity	<a href="#">Page 10</a> <a href="#">Page 10, 11</a>
<b>OPTION Menu, Page4</b> Factory Reset option Setting LCD Backlight and Contrast	<a href="#">Page 11</a> <a href="#">Page 11</a>
<b>BOOST Menu</b> Selecting Boost channel Control Mode Boost Channel Setup Viewing Graph of Boost channel Setup	<a href="#">Page 12</a> <a href="#">Page 13, 14, 15</a> <a href="#">Page 16</a>
<b>AUX Menu</b> Selecting Aux channel Control Mode Aux Channel Setup Viewing Graph of Aux channel Setup	<a href="#">Page 17</a> <a href="#">Page 17</a> <a href="#">Page 17</a>
<b>DATA Menu</b> Viewing Logged Data Erasing Logged Data Operating System Version and Error Codes	<a href="#">Page 18</a> <a href="#">Page 18</a> <a href="#">Page 19</a>
<b>Installation Instructions</b> Wiring and Plumbing Diagram, Boost Channel Wiring and Plumbing Diagram, Aux Channel Optional MAP Sensor Installation Logging, Monitoring Actual Manifold Boost with Aux Channel	<a href="#">Page 20</a> <a href="#">Page 21</a> <a href="#">Page 22</a> <a href="#">Page 22</a>
<b>Specifications</b> Electrical specifications and Dimensions	<a href="#">Page 23</a>
<b>Warranty Information</b> Warranty	<a href="#">Page 24</a>
<b>Quick Tech Tips</b> Tech Tips	<a href="#">Page 25</a>



### Selecting MAP Sensor

Connect the desired MAP sensor as outlined in the Installation section and then follow the instructions below.

**Warning**—Make sure the Selected Sensor matches the one that is installed. All Sensors if connected will re-calibrate. If the wrong one is selected the pressure readings will NOT be correct!

1

Press the OPTION button.

2

Press the SENSOR button.

3

Press BOOST or AUX button to change MAP sensor type.

4

Select New Sensor.

5

Select OK to re-calibrate the new MAP Sensor.

5

Press the BACK button to exit. Use the BACK button to Return to the Main Screen.

Select OK to Return to the Sensor selection screen.

**IMPORTANT INFORMATION**  
If no MAP sensor is detected this message will be displayed and the Sensor setting will NOT be changed!

### Setting Launch Psi, Boost and Aux Channels

The Launch settings will be applied when the Clutch input is ON. Even if the Activation input is ON. The target psi will be overridden by the Launch Psi setting. Scramble and Reduce Inputs will function as normal and Add or Subtract from the Launch setting.

If the Clutch Reset Option is ON all Stage Timers will Reset and the Shift Counter will return to 1st Gear. See the [Clutch Reset Style](#) section for more details.

[Continued on Next Page.](#)

7 **NOTE**—Target Psi is the amount applied to the waste gate and is NOT the actual Manifold Boost Psi!



### Setting Launch Psi, Boost and Aux Channels, Continued...

**1**

Press the OPTION button.

**2**

Press the LAUNCH button.

**3**

Press BOOST or AUX button to adjust the Launch psi setting.

**4**

ESC, Exit and do NOT save new value

Adjust Value.

SAVE, Exit and Save new value.

**5**

Press the BACK button to exit. Use the BACK button to Return to the Main Screen.

### Setting Scramble and Reduce Psi, Boost Channel

When the Scramble Input is ON, the Boost Channel Target Psi will be Increased by the Scramble setting. This function is available in ALL Modes of operation, including Launch Mode (clutch input ON). The Aux Channel is NOT affected by this setting. When the Reduce Input is ON, the Boost Channel Target Psi will be Decreased by the Reduce setting. This function is available in ALL Modes of operation, including Launch Mode (clutch input ON). The Aux Channel is NOT affected by this setting.

**1**

Press the OPTION button.

**2**

Press the NEXT button.

**3**

Press SCRBLE button.

**4**

Press SCRBLE or REDUCE button to adjust.

**5**

ESC, Exit and do NOT save new value

Adjust Value.

SAVE, Exit and Save new value.

**6**





Press the BACK button to exit. Use the BACK button to Return to the Main Screen.



### Setting Activation Hold and Clutch Reset Style

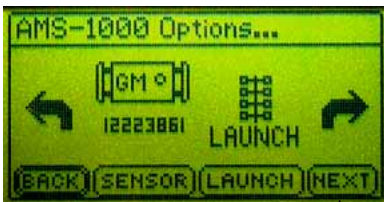

The Activation Hold function when Programmed with a value greater than 0.00 will Delay the release of the Activation Input. i.e.—If the user is using a Wide Open Throttle switch to control the Activation. A Delay could be used to keep the system from re-setting if the throttle is lifted for a short period of time.

If the Clutch Reset Style is ON all Timers and Both channels will be RESET if the Clutch Input is Active (even if the Activation Signal is ON). If the Clutch Reset Style is OFF the system will only RESET when the Activation signal is removed.

- 1  Press the OPTION button.
- 2  Press the NEXT button.
- 3  Press TIMER button.
- 4  Press the ACT,HOLD button.
- 5  ESC, Exit and do NOT save new value. Adjust Value. SAVE, Exit and Save new value.
- 6  Press the BACK button to exit. Use the BACK button to Return to the Main Screen.

### Setting Clutch Reset Style...

Follow Steps 1 through 3 above.

- 4  Press the RESET button to Toggle Clutch Reset On/Off.
- 5  Press the BACK button to exit. Use the BACK button to Return to the Main Screen.

9 NOTE—Target Psi is the amount applied to the waste gate and is NOT the actual Manifold Boost Psi!



### Turning the Aux channel On/OFF

The Aux Channel can be used as a 2nd control channel or it can function as a Live Data readout and logging channel. If the Aux channel is ON (configured for control) the Display will show the actual psi value on the Aux channel. Note—This is the pressure on the control side. And the data log will represent the Actual target psi on the control side.

If the Aux channel is OFF and a MAP sensor is connected to the manifold the Display will provide a live readout of the Actual Manifold Boost pressure. The data log will represent the actual manifold pressure.

Refer to the [Selecting MAP Sensor](#) and the [Installation section](#) for more information...

**1**

Press the OPTION button.

**2**

Press the NEXT button twice.

**3**

Press the AUXOUT button to Toggle the Aux Channel ON/OFF.



**IMPORTANT INFORMATION**  
If no MAP sensor is detected this message will be displayed and the Aux Channel will remain OFF!

### Setting Launch, Shift, Scramble, and Reduce polarity

The Launch, Shift, Scramble, and Reduce inputs can be configured for +12 volt or Ground activation. This way existing wiring and/or switch setups can be used.

**1**

Press the OPTION button.

**2**

Press the NEXT button twice.

**3**

Press the INPUT button.

Continued on Next Page.



**Setting Launch, Shift, Scramble, and Reduce polarity, Continued...**



Press button to change Polarity

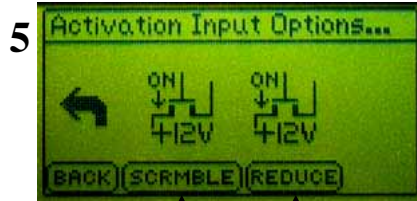

Press button to change Polarity

Press the BACK button to exit. Use the BACK button to Return to the Main Screen.

**Factory Reset option**

The Factory Reset option will return all controller settings to their factory defaults.

**Warning**—All current settings will be lost if a Factory Reset is done!



Press the OPTION button.



Press the NEXT button three times.



Press the RESET button.

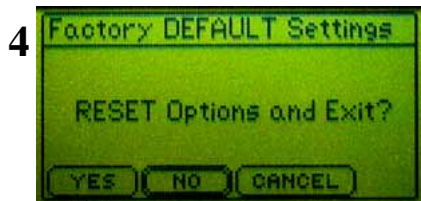

Confirm Factory Reset.

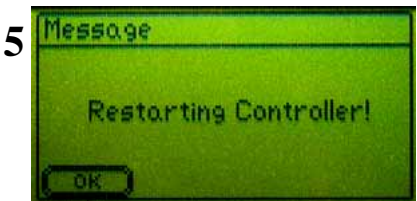

Press OK.

**Setting LCD Backlight and Contrast**



Press the OPTION button.



Press the NEXT button three times.



Press the LCD button to go to the LCD options page.

11 NOTE—Target Psi is the amount applied to the waste gate and is NOT the actual Manifold Boost Psi!



## Selecting Boost Channel Control Mode

Multiple operating modes are available as outlined on [Page 3](#). Time based, Shift based, and GPS (gear position sensor) based.

Boost Channel Mode



Press the BOOST button.

Note—GPS mode can only be selected using the Boost setup menu. When using GPS mode the Aux channel will be configured for GPS mode also.

Time based or Shift based modes can be used for the Boost and Aux channels. i.e.—Boost channel could be Time based and the Aux channel could be Shift based.



Press the STYLE button to change operating mode.

Time Based—One to six timed stages are available with this mode of operation. Each stage has an adjustable timer to control the duration. The Ramp Rate (rate at which the pressure is applied) is adjustable from 0 to 100 psi per second. A Ramp Rate setting of 0 does not disable the stage. The target psi will instantly rise at the end of any timed stage with a 0 Ramp Rate setting. The target psi can be increased or decreased over time to achieve the desired Boost Profile.

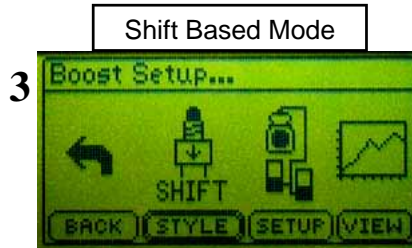

Shift Based—One to six stages are available and are controlled by a Shift Input signal. The Ramp Rate for each stage is programmable as well as the Target psi for each stage (gear position). The Ramp Rate settings perform the same functions as in Time Based mode.

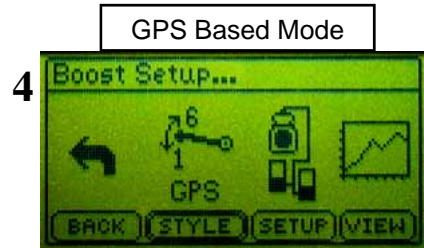

GPS Based—One to six stages are available and are controlled by a 0-5 volt analog Input signal. This mode is for newer sport bikes or any vehicle that produces a different voltage for each gear position. A switch that produces a different voltage for each position can be used to select different boost profiles (up to six) on vehicles that do not use a Gear Position Sensor system. The Ramp Rate for each stage is programmable as well as the Target psi for each stage (gear position). The Ramp Rate settings perform the same functions as in Time Based mode. Data logging is NOT available with this mode of operation.



## Boost Channel Setup

### Setting number of Control Stages, All Modes

1 Press the SETUP button.

2 Press the STAGE button.

3 ESC, Exit and do NOT save new value      Adjust Value.      SAVE, Exit and Save new value.

### Setting Delay Timer, Shift Mode ONLY!

1 Press the DELAY button.

2 ESC, Exit and do NOT save new value      Adjust Value.      SAVE, Exit and Save new value.

When in Shift Mode this setting will Delay the Activation or Boost Control until the Delay Timer has elapsed. i.e.—can be used to hold and/or delay the Launch psi while launching in 1st gear.

### Setting control stage parameters

1 Press the NEXT button.

2 BACK, exit edit view.      Select Cell for Editing.      EDIT, Edit Cell value.

[Continued on next page...](#)



**STAGE TIME IN SECONDS—Time Based mode ONLY!**, This setting determines the Time for Each Stage when using Time Based mode. To determine the total time for all stages add the Time for each Stage together. Please see the example below for more details.

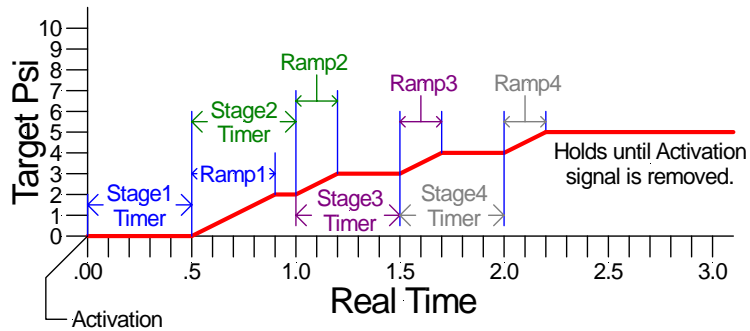

**1**

Select Cell for Editing.

**2**

Press the EDIT button.

**3**

ESC, Exit and do NOT save new value

Adjust Value.

SAVE, Exit and Save new value.

**RATE, PSI PER SECOND—All Modes**, This setting determines the Rate the Target Psi is applied. The range is 0 to 100 psi per second. A setting of 0 will apply the Target psi immediately with no Ramp. The Ramp will be applied at the end of each stage when in Time Based mode.

When in Shift or GPS modes the Ramp will be applied on each gear change. If the Target psi is not fully applied and a gear change occurs the Ramp rate for the next stage will be used.

An Optional delay timer is available in Shift mode only. This can be used to delay the Ramp for 1st gear only.

**1**

Select Cell for Editing.

**2**

Press the EDIT button.

**3**

ESC, Exit and do

Adjust Value.

SAVE, Exit and Save new

[Continued on next page...](#)



**TARGET PSI—All Modes,** This setting determines the Target Psi for each stage. The range of Adjustment depends upon the MAP Sensor being used. The range is automatically scaled for current MAP sensor selected. The Target Psi can be increased or decreased for each stage.

**NOTE**—It is possible to set a Target Psi value that can NOT be reached. This occurs when the Ramp Rate and/or Stage Time does not permit the full Target Psi setting to be achieved. i.e.—If a Stage Time of 1 second, Ramp Rate of 2 Psi Per Second, and a Target Psi of 4. The controller would only be able to apply 2 Psi in the 1 Second programmed for the stage. The only exception to this is the Last Stage. The Last Stage Target Psi will always go to the programmed setting (unless the Activation signal is removed).

1

2

3

Select Cell for Editing.

ESC, Exit and do NOT save new value

Adjust Value.

SAVE, Exit and Save new value.

**VOLTS, GPS INPUT VOLTAGE—GPS Mode ONLY,** The GPS voltage is used to determine what gear the vehicle is in. The voltage for each gear position can be entered manually or a setup wizard is provided. A switch that provides a different voltage for each setting can be used to select up to 6 different boost profiles. The input will accept a +/- .1 volt input difference from the programmed value. The current GPS Input Voltage and Gear Position will be displayed on the Main Screen when GPS mode is active.

1

2

GPS voltage, manual entry.

Press the EDIT button.

Manual setup.

Use Setup Wizard.

ESC, Exit and do NOT save

Adjust Value.

SAVE, Exit and Save new value.

**GPS Wizard Instructions,**

To use the wizard simply put the vehicle in the gear displayed and press **ENTER**. Select **YES** to accept the current Gps Voltage or **NO** to manually set the voltage. This option will only work on vehicles that provide a voltage (0 to 5 volts) for each gear position. You may move through the gear positions using the **ARROW** button.

Use the **RANGE** button to adjust the voltage +/- voltage range for the selected gear position. Valid range is .1(.2 volt range) to .5(1 volt range) volts. It is common for the GPS voltage to change vary with the engine running.

Press the **DONE** button when finished. If a voltage is present on the GPS (Activation) Input that is not recognized the Target Psi will be set at 0.



**Viewing Graph of Boost channel Setup**—The current boost channel setup can be viewed in graph form. Use the Arrow buttons to navigate through the setup. In Shift and GPS modes a .1 second time is added to the end of each stage (for viewing purposes only). If the Launch Psi setting is greater than 0 the user can include the Launch setting in the graph data.

**1**

**2**

**Without Launch Data.**

**3**

**With Launch Data.**



## Selecting Aux Channel Control Mode

Multiple operating modes are available as outlined on [Page 3](#). Time based, Shift based, and GPS (gear position sensor) based. Only GPS mode will be available if the Boost channel is configured for GPS mode.

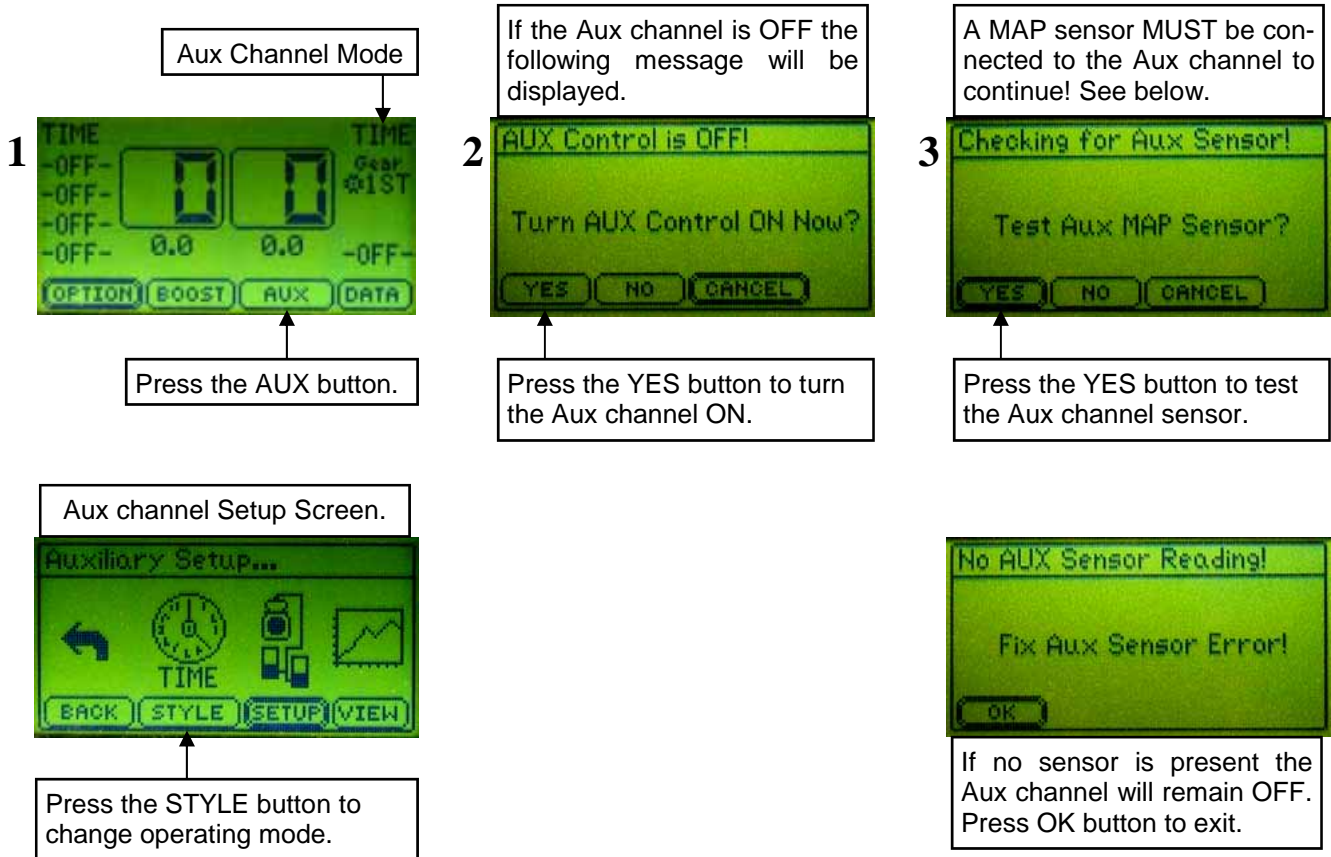

## Aux Channel Setup

After entering the Aux channel setup refer to [Boost Channel Setup](#) (page 13) for more information.

## Viewing Graph of Aux channel Setup

After entering the Aux channel setup refer to [Viewing Graph of Boost channel Setup](#) (page 16) for information.



### Viewing Logged Data

The actual Target Boost Psi and Aux Target Psi is recorded (logged) for viewing and tuning purposes. Data logging will occur if the Data memory is erased and the Activation signal is present. Data logging will begin when a +12 volt signal is applied to the Activation Input.

The Boost and Aux channels will record data for 35 seconds (less if the Activation signal is removed). When the Activation signal is removed the logged data will be written to EEPROM memory for later viewing. The logged data will be stored even if the controller is turned OFF. The ONLY way to record over the logged data is to erase it.



1 Press the DATA button.

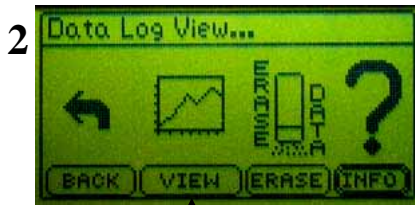

2 Press the VIEW button.

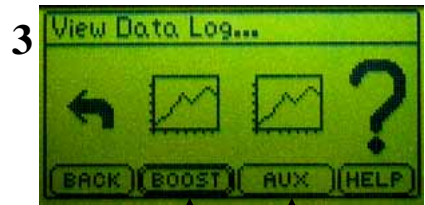

3 Select Channel to View.



4 Exit

Navigate Data

**Note**—The Activation signal must be removed before turning off the unit for Data to be stored to non-volatile memory. If the Activation signal is connected directly to the #8 Switched +12V Power terminal the Data Log function will not work correctly!

### Erasing Logged Data

Follow the instructions below to erase current data log.



1 Press the DATA button.

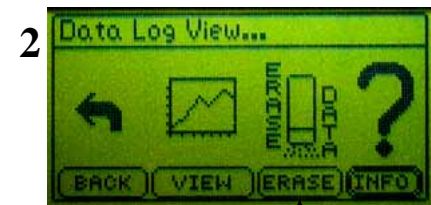

2 Press the ERASE button.

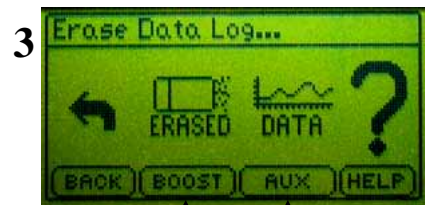

3 Select Channel to Erase.



## Operating System Version and Error Codes

The operating system can be updated by the factory. Use the instructions below to obtain the current Version Information.

Any error that may occur will be stored as a number code and can be retrieved for diagnostics. Error codes can be erased after viewing. See below for details.

**1**



Press the DATA button.

**2**

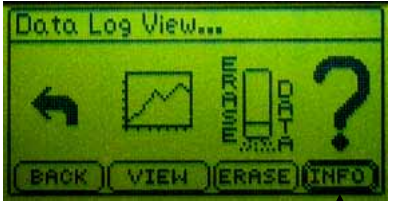

Press the INFO button.

**3**



Check for Error Codes.

No Error Codes Present.

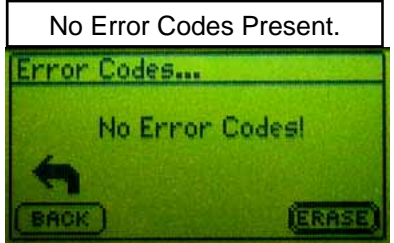

Error Codes Present. Codes will be displayed from left to right. Left most codes are the oldest and the far right code is the most recent.

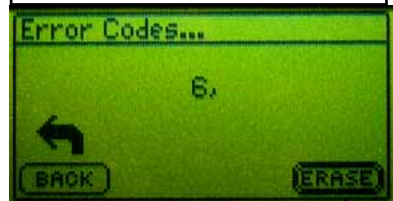

Press to Erase Code History.

### Code Listing

- 0—Boost Input Analog to Digital system Timeout Error.
- 1—Aux Input Analog to Digital system Timeout Error.
- 2—GPS Input Analog to Digital system Timeout Error.
- 3—Memory Exception Error, Illegal memory access.
- 4—Illegal Opcode Error, unrecognized CPU instruction.
- 5—Memory Allocation Error.
- 6—Boost MAP Sensor Error.
- 7—Aux MAP Sensor Error.



## Wiring and Plumbing Diagram, Boost Channel

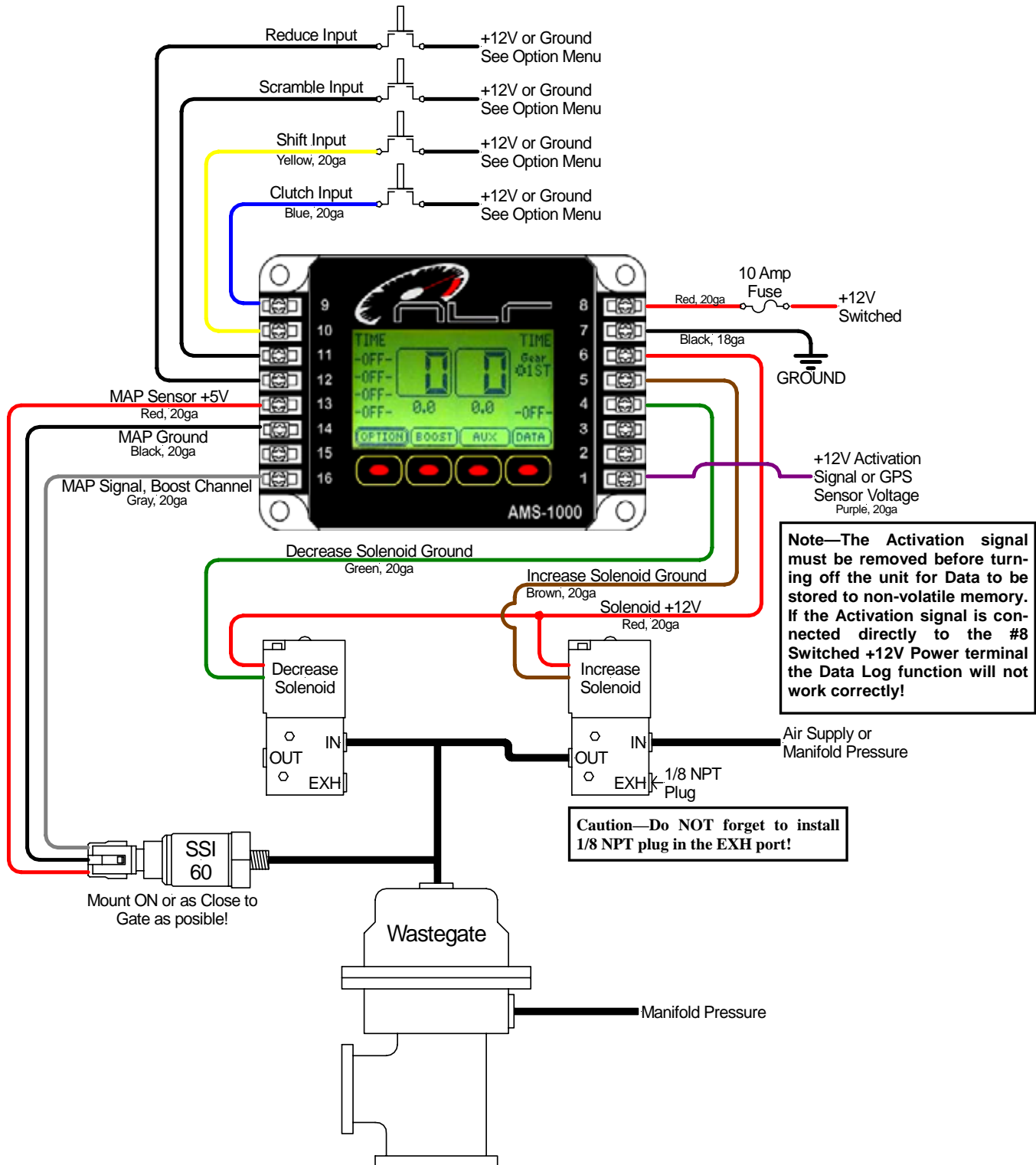

20 **NOTE—Target Psi is the amount applied to the waste gate and is NOT the actual Manifold Boost Psi!**



## Wiring and Plumbing Diagram, Aux Channel

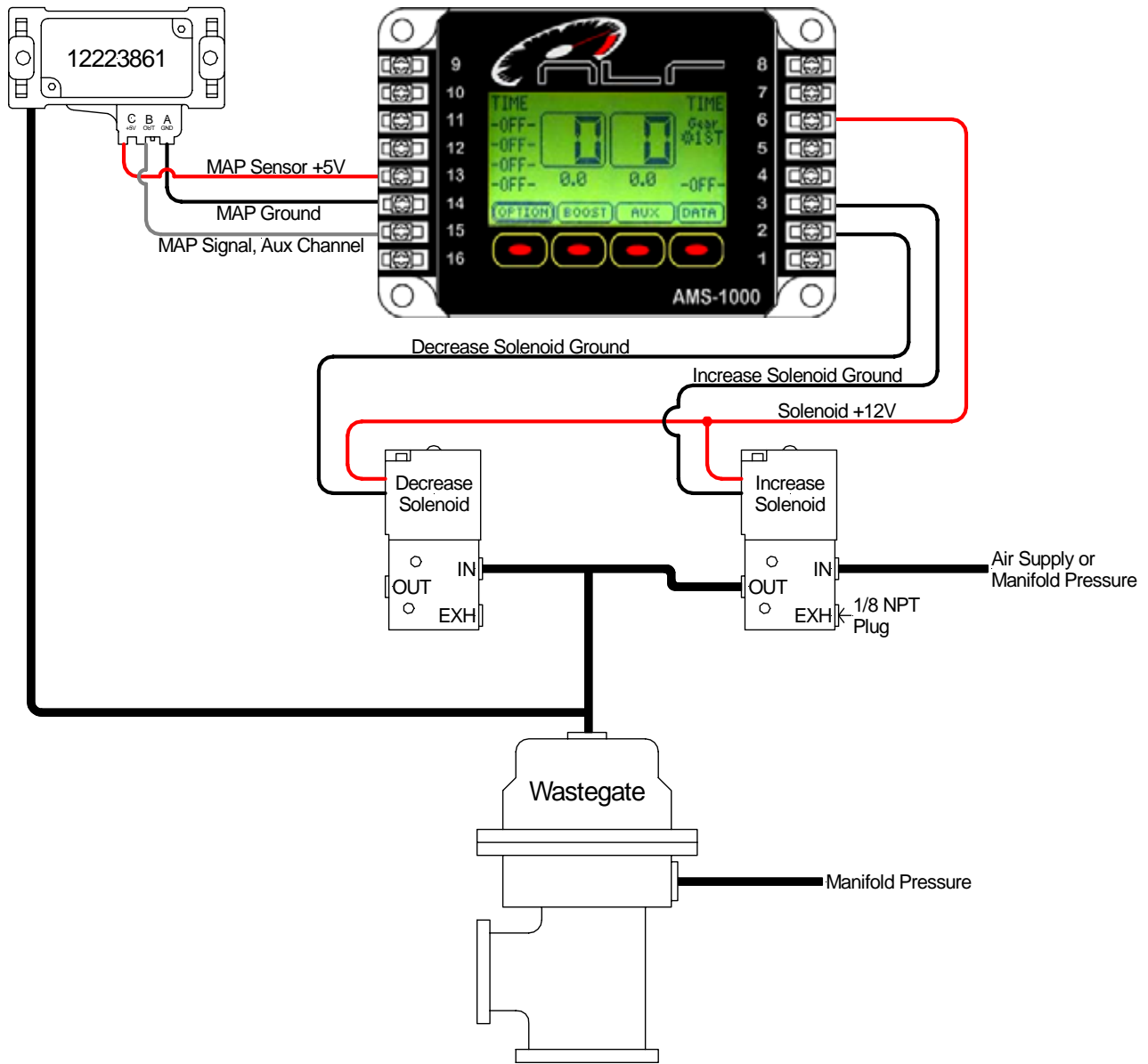

21 NOTE—Target Psi is the amount applied to the waste gate and is NOT the actual Manifold Boost Psi!



### Optional MAP Sensor Installation

The optional sensor must be configured using the OPTION menu. See [page 7](#) for details.

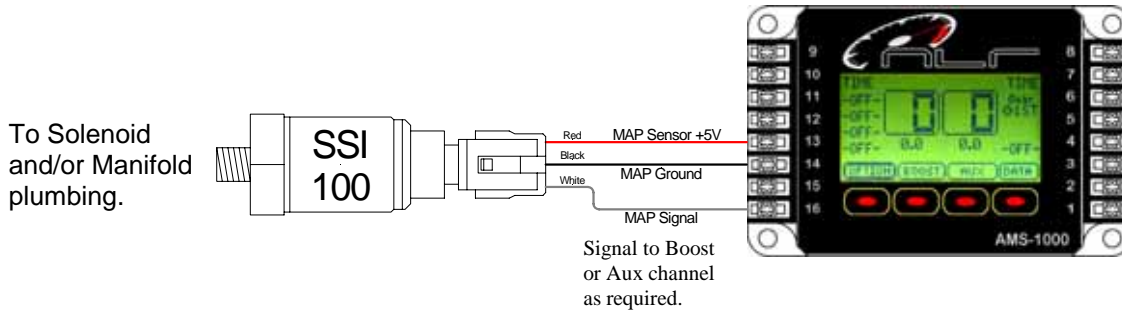
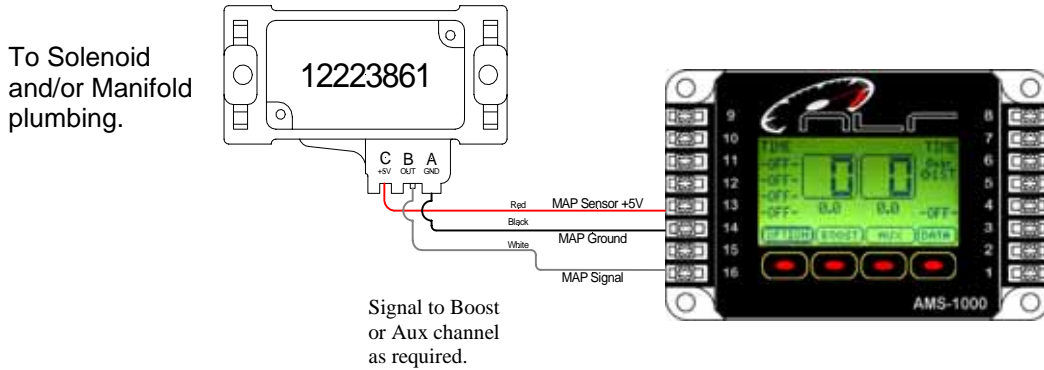

### Logging, Monitoring Actual Manifold Boost with Aux Channel

When the Aux channel is NOT used for control it may be used to monitor and data log the Actual manifold boost pressure. Connect the MAP sensor to the Aux channel as outlined. Connect the sensor port to the manifold. The AUX readout will now display the actual manifold pressure.

If data logging is enabled (Aux channel erased) the actual manifold pressure will be logged. This can then be compared to the Boost channel data for tuning purposes.

**NOTE—When monitoring manifold pressure the Engine must be OFF when the AMS-1000 is turned on. If the engine is running the Sensor calibration will be in-correct!**

Connect Sensor port to Manifold.

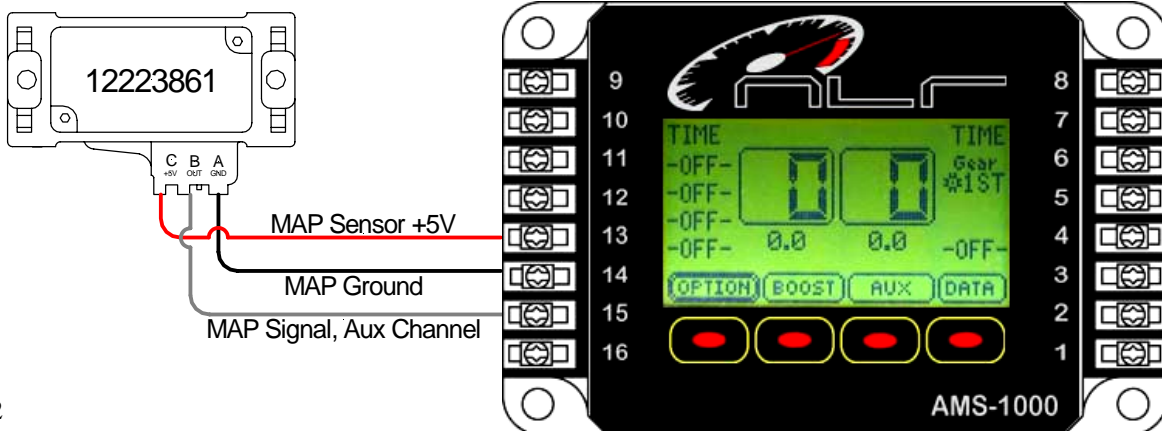



## Specifications

Normal Operating Voltage— 10 to 16 volts (Controller will function down to 7 volts, Solenoids need a minimum of 10 volts for proper operation).

Maximum Current— 5 Amps for each Solenoid Output.

MAP Sensor Input— 0 to 5 volts.

GPS Input— 0 to 5 volts.

Overall Height— .975"  
 Overall Width— 2.850"  
 Overall Length— 4.350"

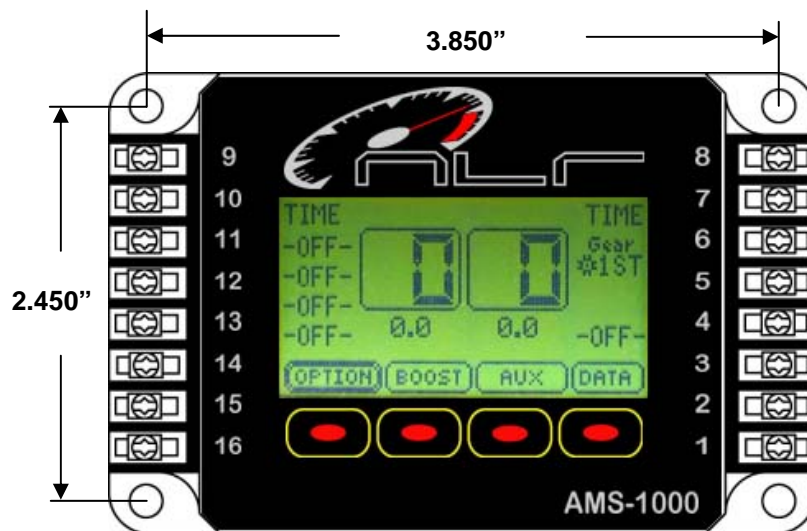



## Warranty Information

NLR, LLC warrants to the original purchaser that the AMS-1000 Controller Shall be free from defects in parts and workmanship under normal use for 6 months from the date of purchase.

NLR, LLC obligation under this warranty is limited to the repair or replacement of any component found to be defective when returned postpaid to NLR, LLC.

The Controller must be returned with evidence of place and date of purchase or warranty will be void. The warranty will not apply if the AMS-1000 Controller has been installed incorrectly, repaired, damaged, or tampered with by misuse, negligence or accident.

Phone 334-741-7100

## Viewing Terminal Pin Descriptions on Screen

- 1 

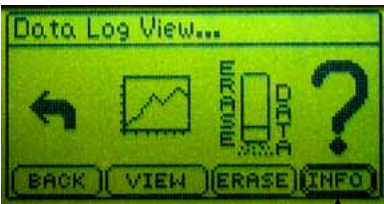
Press the DATA button.
- 2 

Press the INFO button.
- 3 

Press the PINOUT button.
- 4 

Press the BACK to Exit.



### Quick Tech Tips:

1— If you are going to use the AMS-1000 in time based or shift input mode(not GPS) you will need to supply switched 12 volts to terminal number 1. This input will need to be turned on and off. Think of it like this, when the switch is off(not supplying 12 volts to terminal number 1) the AMS-1000 is in PROGRAM mode, allowing you to make changes to the program. When the switch is on(12 volts being applied to terminal number 1) the controller is in RUN mode and will not let you make changes as it is trying to run its program. This is an activation input , you will still need to supply power to terminal 8 and a ground to 9. PLEASE SEE INSTRUCTIONS FOR MORE INFORMATION!

2 — Make sure you configure the input polarity for the (shift, clutch, scramble, reduce) before you connect your wires. If you have it configured for the wrong polarity the input will go on and stay on. If this has happened removed the wire and go in and change the input polarity and reconnect the wire. PLEASE SEE INSTRUCTIONS FOR MORE INFORMATION!

3 — Clutch input can be used as a transbrake input.

4 — Mounting the pressure sensor in the gate will have the best results. Drill and tap for a 1/8 npt and screw in sensor. Mount solenoids as close to gate as possible. If you cannot mount sensor in the gate then tee it in as close as possible.

5 — Co2 as pressure source is recommended as it has many benefits. Run as small as a spring as you can and let the controller do the rest!